

NITRO HD

8100 HD Monitor

Installation, Operating, Maintenance, & Troubleshooting Instructions



TABLE OF CONTENTS

PRODUCT SAFETY INFORMATION	3
MONITOR CALLOUT DRAWING	4
SYSTEM COMPONENTS	5
INSTALLATION INSTRUCTIONS	7
Installation Step 1: Mount the System Components	7
Installation Step 2: Wiring the System Components	9
Installation Step 3: Check Installation	11
OPERATING INSTRUCTIONS	12
MAINTENANCE INSTRUCTIONS	15
TROUBLESHOOTING GUIDE	16
SYSTEM SPECIFICATIONS	18
MONITOR AND NOZZLE HYDRAULIC DATA	19
COMPONENT MOUNTING TEMPLATES	21

PRODUCT SAFETY INFORMATION

- All personnel who may be expected to use this equipment must be thoroughly trained in its safe and proper use.
- Before flowing water from this device, check that all personnel are out of the stream path. Also, check to make sure stream direction will not cause avoidable property damage.
- Become thoroughly familiar with the hydraulic characteristics of this equipment, and the pumping system used to supply it. To produce effective streams, operating personnel must be properly trained.
- Whenever possible, this equipment should be operated from a remote location. Do not needlessly expose personnel to dangerous conditions.
- Open water valves supplying this equipment slowly so that piping fills slowly, thus preventing possible water hammer occurrence.
- After each use, and on a scheduled basis, inspect equipment per instructions in the Maintenance section.
- Any modifications to the system may destroy the NEMA 4 rating and void warranty coverage.



Important: Before installing and operating provided equipment, read this manual thoroughly. Proper installation is essential to safe operation.

SYSTEM INFORMATION:

MONITOR SERIAL NUMBER: _____ MODULE SERIAL NUMBER: _____
NOZZLE SERIAL NUMBER: _____ JOYSTICK SERIAL NUMBER: _____

SYSTEM NOTES: (System application, 12/24 VDC operation, valve operations, ETC.):



Nitro HD Monitor

SYSTEM COMPONENTS

MONITOR

Nitro HD Monitor – 8100 HD

The Nitro HD monitor is specially designed for severe duty cycles. Unique waterway swivel joints utilize stainless steel thrust rods and needle roller thrust bearings for unprecedented durability in mining and construction applications. High power, permanent magnet DC gear motors that drive the left-right and up-down monitor motions are NEMA 4 rated for use in harsh environments. The monitor has a flow efficient 2¼" vaned waterway to minimize turbulence and provide superior nozzle streams. The water supply connection in the monitor base is a 2½" female national pipe thread, and the discharge nozzle connection has a 2½" national hose male thread.



8100 Monitor (00008101)

NOZZLE

7000-EHD Nozzle –

The 7000-EHD is a fixed flow nozzle designed specifically for use in mining and construction applications. The nozzle stream can be electronically adjusted from a straight stream to full fog patterns. Bellows covers are included to protect the nozzle's moving parts from dust and debris.

The 7000-EHD nozzle comes with a fixed stem that provides either 750, 500, 350, or 200 GPM of flow at a nozzle base pressure of 100 PSI (depending on the nozzle version ordered). The nozzle flow profile can be altered by ordering and installing one of the other stem sizes if desired. Please contact Elkhart Brass support staff to inquire about obtaining additional stem options.



7000-EHD (P/N: 07000804)

200 GPM – P/N: 07000801

350 GPM – P/N: 07000802

500 GPM – P/N: 07000803

750 GPM – P/N: 07000804

CONTROL

Nitro HD Joystick - 41067000

The Nitro HD joystick controller provides basic directional movement of the monitor and allows the customer to actuate the electronically controlled nozzle. Additionally, a maintained pushbutton trigger is supplied on the joystick handle as an external switch for opening and closing a valve or other auxiliary device. The joystick can be mounted to a panel either in or out of its provided enclosure depending on panel space and customer preference.



Nitro HD Module – 81824001

The Nitro HD Module provides communication between the monitor and joystick and in combination with harness 37523000 allows customers to attach external power and ground connections. The Nitro HD system can be powered with 12 or 24 VDC. The module housing is made of durable Nylon 6/6 and seals to NEMA 4 standards.



MONITOR ACCESSORY

Nitro HD Harnesses – 37522000, 37523000, 37527000

To make the wiring of the Nitro HD system as simple as possible, Elkhart Brass has created harnessing specifically intended for use between the Nitro HD components. Each of the harnesses is fitted with either a different size or key type so that the system cannot be wired incorrectly during installation.

Harness 37522000 is a 15 foot long module-to-monitor harness intended to be installed between the Nitro HD Module and Monitor. Harness 37523000 is an 8 foot long module-to-joystick harness intended to be installed between the Nitro HD Module and Joystick. The 37523000 harness has power and ground leads which allow the Nitro HD System to be connected to an appropriate power source. Harness 37527000 is a 15 foot long extension harness to extend the distance between the Nitro Module and Joystick if required for a particular installation. Up to five 37527000 harnesses can be used in conjunction to accommodate even longer length requirements.



INSTALLATION INSTRUCTIONS

Installation Overview:

- Step 1 – Mounting the System Components
- Step 2 – Wiring the System Components
- Step 3 – Check Installation

Installation Step 1: Mounting the System Components

Nitro HD Monitor –

- Before mounting the monitor, ensure that space allows for the monitor to be rotated fully. (The Nitro HD monitor is capable of either 180 or 350 degrees horizontal travel and either 90 or 135 degrees of vertical travel depending on the sensor mounting location used)
- Thread monitor onto a male 2.5” NPT thread using Loctite 592 or equivalent thread sealant. Tighten using a strap wrench on the hex portion of the monitor base.
- Use the cast arrows on the monitor base and body to determine the center horizontal position of the monitor.
 - The cast arrow on the monitor base designates the center horizontal position of the monitor. The monitor will be able to rotate from this position equally to the left and to the right. The amount of this rotation will depend on the mounting location of the sensors. For more on setting the rotation angles of the monitor, refer to the operation section of this manual.
 - When the cast arrow on the monitor body is pointing at the cast arrow of the monitor base, the monitor is pointing at its horizontal center position.

7000-EHD –

- Ensure there is a gasket inside the nozzle swivel.
- Position the nozzle on the monitor with the actuator on top before tightening the nozzle to the monitor.
- Hand tighten the nozzle onto the monitor discharge, then tighten the nozzle swivel with a spanner wrench.
- Connect the nozzle Deutsch connector to the mating Deutsch connector of the monitor.

Nitro HD Module –

- Locate an appropriate mounting place for the Nitro Module. Although the module is sealed and made of durable nylon 6/6 material, the module should be placed in a location that will protect it from high pressure sprays and incidental contact with objects that may be capable of breaking the module enclosure.
- Mount the module onto a flat surface using two appropriate length 1/4” or 6mm fasteners in the provided mounting holes.

- A mounting hole template for the module can be found in the Component Mounting Templates section.

Nitro HD Joystick

Depending on customer preference, the Nitro Joystick may be mounted in one of two ways. The Joystick can be mounted on top of a panel by leaving the joystick in its provided enclosure, or the joystick can be mounted flush with a panel by removing the joystick from its provided enclosure. Installation instructions will vary based on these options.

NOTE: The side of the joystick with the push button trigger is considered the front of the Joystick.

Mounting Joystick on top of a Panel:

- Locate an appropriate mounting place for the Nitro Joystick. The Nitro Joystick is not a sealed component and should be mounted inside a cab or other compartment where it will not come into contact with water or other liquids.
- Remove the joystick lid by loosening the four Phillips screws holding it in place.
- Mount the joystick enclosure onto a flat surface using four appropriate length #8 or M4 fasteners in the intended mounting holes.
 - A mounting hole template for the joystick enclosure can be found in the last section of this manual.
- After attaching the joystick enclosure to the panel top, reattach the lid with the four Phillips screws.

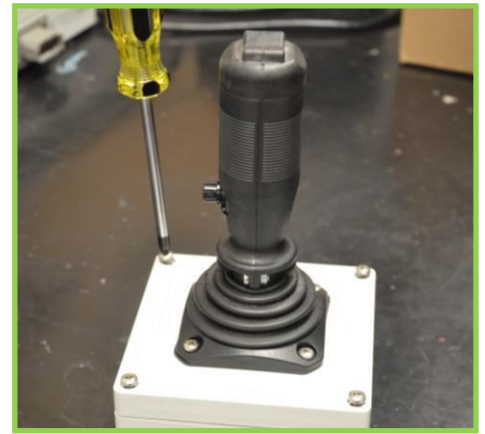

Mounting Joystick flush with the Panel:

- Locate an appropriate mounting place for the Nitro Joystick. The Nitro Joystick is not a sealed component and should be mounted inside a cab or other compartment where it will not come into contact with water or other liquids.
- Remove the joystick lid by loosening the four Phillips screws holding it in place.
- Disconnect the joystick wiring from the enclosure harness by disconnecting the 6 pin connector inside the enclosure.
- Remove the four Phillips screws holding the joystick to the enclosure lid and pull off the top flange.



- Squeeze the joystick boot and push the joystick handle down through the enclosure lid.
 - The enclosure box, lid, and harness can be discarded.
- Drill and cut the appropriate clearance holes in the panel.
 - A mounting hole template for the joystick can be found in the last section of this manual.
- Insert the joystick handle through the underside of the panel and pull the boot through the cutout so it sits on top of the panel.
- Lower the joystick flange down over the handle so it covers the flat portion of the boot.



- Secure the joystick to the panel with the same four Phillips screws that once held it to the enclosure lid.

Installation Step 2: Wiring the System Components

Nitro HD Monitor –

- Remove the nameplate cover by loosening the three 8-32 screws holding it in place.
- Connect the green 12-position Deutsch plug of harness 37522000 to the green 12-position Deutsch receptacle of the monitor.
- Tuck the wires into the wire housing cavity and reattach the nameplate cover. Apply blue Loctite #242 or an equivalent thread locking compound to the screw threads.
- Secure harness 37522000 to the monitor body with the ½” clamp loop at the bottom of the monitor body. Apply blue Loctite #242 or an equivalent thread locker to the screw threads.

Nitro HD Joystick –

- Wiring of the Joystick controller is the same whether it is mounted on top of, or flush with, a panel.
- Locate the 6-position gray Deutsch receptacle of the joystick controller and connect it to the 6-position gray Deutsch plug of harness 37523000.
- Maintained Pushbutton Trigger –
 - There is a single purple wire with a 18 gauge butt splice located on the underside of the joystick controller. Connect to this splice to utilize the maintained pushbutton trigger functionality.
 - The maintained pushbutton will provide switching function only, and does not control a relay.

- To access the pushbutton wire through the enclosure, the strain relief can be loosened and a wire can either be inserted from the outside of the enclosure, or the purple wire and butt splice can be pulled out from the inside of the enclosure.
- If more length between the joystick and module is needed, up to 5 extension harnesses (P/N 37527000) may be added to allow up to 75 feet additional length.

Nitro HD Module –

- Connect the black 12-position Deutsch connector of harness 37522000 to the receptacle connection labeled 'To Monitor' on the module.
- Connect the gray 12-position Deutsch plug of harness 37523000 to the receptacle connection labeled 'To Joystick' on the module.
- Using the adhesive-lined butt splices, connect the red and black leads from the Nitro Module (Harness 37523000) to an appropriate power source.
 - Connect the red lead to either 12 or 24 VDC power. Connect the black lead to ground.
 - Use 12 AWG wire between the power source and the Nitro leads.
 - Install a 20 Amp fuse into the positive power lead for a 12VDC system (10 Amp for 24VDC system) to protect the Nitro System components.
 - The Nitro HD module provides 12 VDC output to monitor and nozzle motors even when supplied with 24 VDC.

Installation Step 3: Check Installation

After mounting and wiring the Nitro System, check the installation of each component before powering on and operating the system.

- Ensure that all components have been mounted securely.
- Ensure that the components have been wired together correctly.
- Ensure that a fuse has been installed in the positive power lead of the system.

Power on and operate the system to check for correct functionality.

- Ensure that the monitor and nozzle do not contact or interfere with other objects mounted nearby.
 - If adjustment to the rotation angles is needed, refer to the operation section of this manual. (The Nitro HD monitor is capable of either 180° or 350° Horizontal rotation and either 90° or 135° Vertical rotation, depending on sensor mounting locations.)
- Ensure that both directional movement of the monitor and nozzle stream/fog operation is correct.
- If the maintained pushbutton trigger is being utilized, test the trigger functionality as well.

OPERATING INSTRUCTIONS

Basic Operations

For the following monitor and nozzle movements the side of the joystick with the pushbutton trigger is considered the front of the joystick handle. For diagonal monitor movement, simply perform the two directional movements at the same time.

UP Monitor Movement – Pull back on the joystick handle

DOWN Monitor Movement – Push forward on the joystick handle

RIGHT Monitor Movement – Pull the joystick handle to the right

LEFT Monitor Movement – Pull the joystick handle to the left

TO STREAM Nozzle Movement – Press and hold the right rocker switch

TO FOG Nozzle Movement – Press and hold the left rocker switch

Monitor Rotation Limits

The Nitro HD monitor is capable of either 180° or 350° Horizontal rotation and either 90° or 135° Vertical rotation, depending on sensor mounting locations as described below.

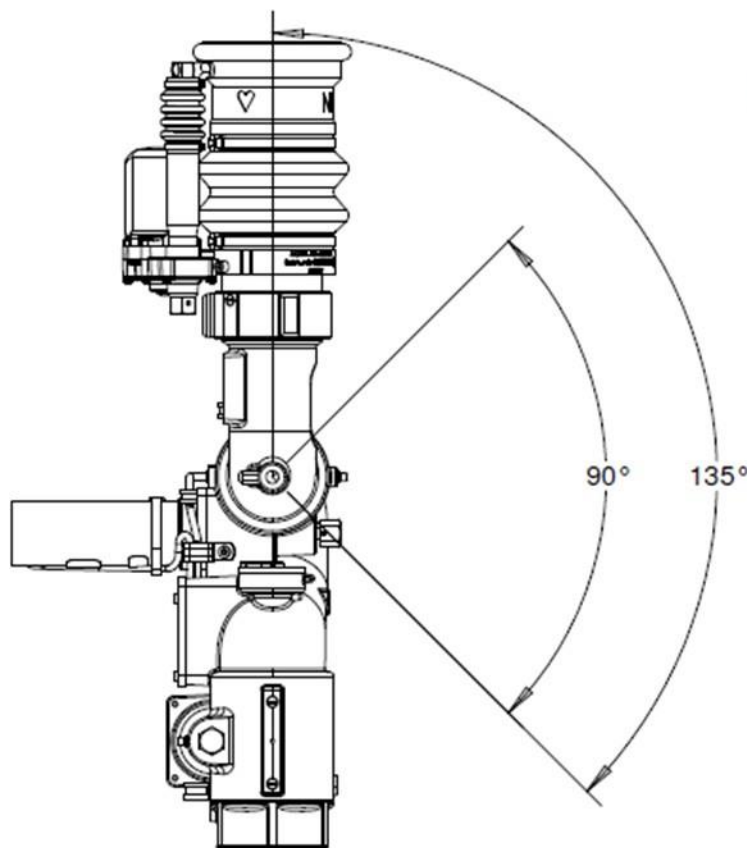

VERTICAL ROTATION ANGLE
DETERMINED BY MOUNTING
POSITION OF VERTICAL SENSOR

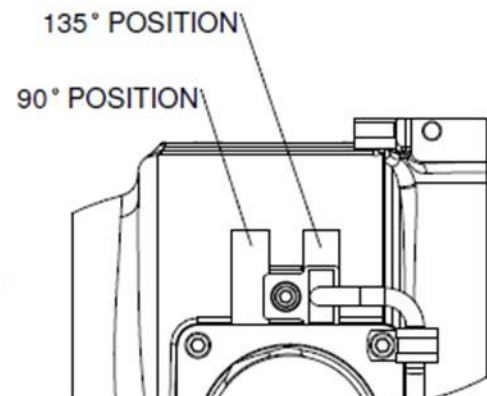

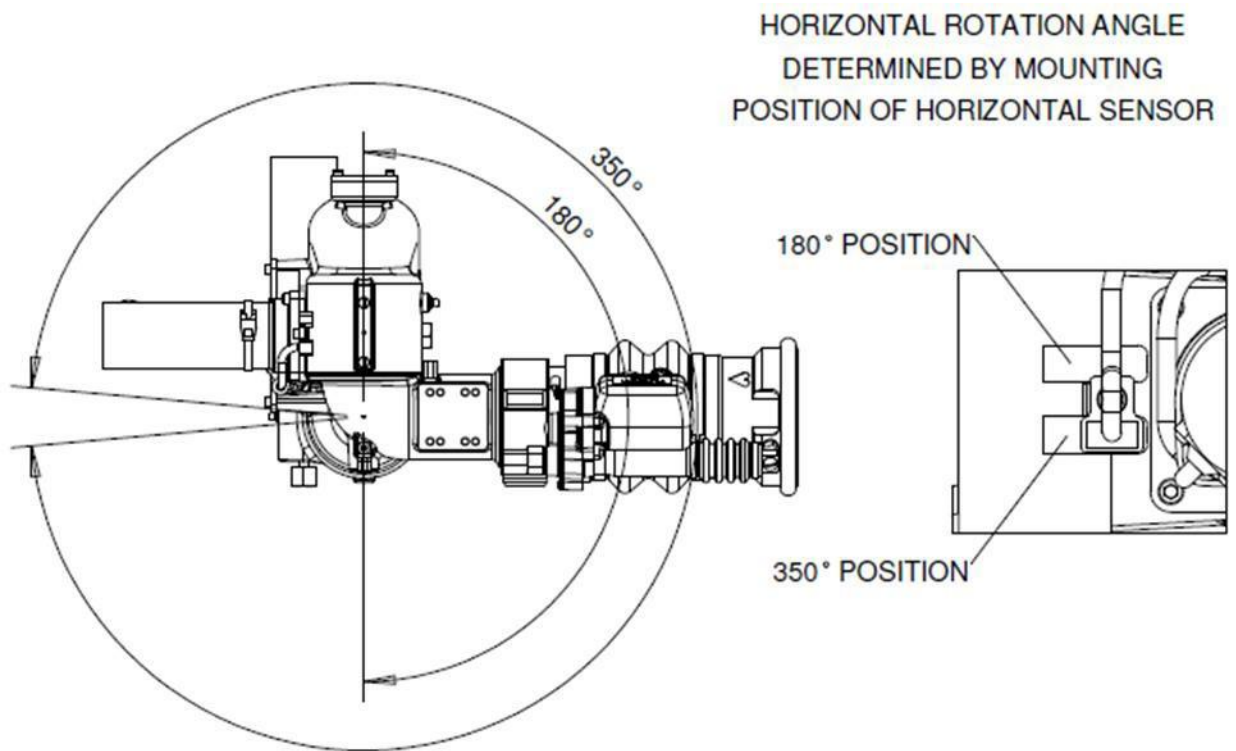

Changing the rotation limits of the monitor:

- Locate the sensor and remove the 8-32 screw, lock washer, washer holding it in place.
- Reposition the sensor into the desired rotation track.
- Reattach the sensor to the monitor body with the same 8-32 screw, lock washer, and washer. Tighten the screws to 20 in-lbs.



Caution: Overtightening of the screws may damage the sensor.

- Readjustment of the sensor wiring may be required to reach the intended rotation track. This may require removal of clamp loops or the monitor nameplate cover to create more slack in the sensor wiring. Replace any items that have been removed and apply blue Loctite #242 or an equivalent thread locking compound to the screw threads.

Trigger Operation

The trigger on the joystick handle is a maintained pushbutton switch. If the customer has not connected the pushbutton wiring independent of the basic system wiring setup, the pushbutton will have no function. Function of the pushbutton switch will otherwise depend on what the switch has been connected to. The maintained, or latching, pushbutton will become closed when pushed and will stay closed until the button is pressed again.

Changing the Nozzle Stem

The 7000-EHD nozzle can have its pressure and flow profile altered by changing out the fixed stem used with the nozzle. Currently there are four stem choices for use with the 7000-EHD nozzle. These are the 750 GPM, 500 GPM, 350 GPM, and 200 GPM fixed stems.

- To change out the nozzle stem, begin by removing the nozzle from the monitor and disconnecting power to the nozzle.
- Next, using a 1/4" T-Handle wrench, loosen and remove the current stem from the nozzle assembly.
 - To ensure that the stem and stream shapers do not just spin, a 7/32" T-Handle wrench can be used on the opposite side of the nozzle to hold the stream shaper bolt into place.

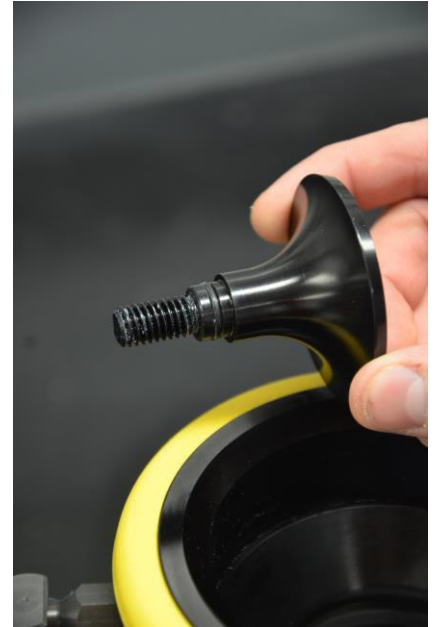

- Once the stem has been removed, locate the new stem and ensure that an AS-568-012 O-Ring has been placed into the groove on the threaded end of the stem.
- Once an O-ring has been installed on the stem, apply blue Loctite #242 or an equivalent thread locking compound onto the stem's threads.
- Finally tighten the new stem into the nozzle assembly with the 1/4" T-Handle wrench.
 - Again a 7/32" T-Handle wrench may be used on the opposite end of the nozzle to ensure the stream shapers do not just spin when attempting this stem installation.

If the stream shaper bolt has become loose during the stem change process, apply red Loctite #262 or an equivalent thread locking compound onto the bolt's threads and reassemble it into the nozzle ensuring that the stream shapers are pushed as far forward to the nozzle's discharge end as possible. Failing to push the stream shapers completely forward during nozzle reassembly will result in altered flow performance of the nozzle and failure to reach rated flows at stated pressures. Please contact Elkhart Brass if further assistance is needed.

MAINTENANCE INSTRUCTIONS

Preventive Maintenance

The complete Nitro System should be inspected during each apparatus check and at least once a month on a scheduled basis. Careful inspection for damage to the monitor and nozzle is especially important.

- Visually inspect each Nitro System component including the Monitor, Nozzle, Joystick, Module and intermediate wire harnesses.
 - Look for signs of excessive wear or abnormal damage.
 - Look for loose mounting or wiring connections.
- Operate the system as outlined in the installation section to ensure that all intended operation of the system is correct.
- Flow water to check the nozzle pattern
 - If the pattern is disrupted, clear the debris
 - If the obstruction still remains, remove the nozzle and check for debris lodged between the nozzle stem and monitor or in the nozzle stream shapers
- During the nozzle flow test, inspect monitor swivel joints for leaks
- Inspect all exposed wiring for signs of damage

Note: Grease fittings are provided for the up-down and left-right gear cases. Routine greasing should be done. It is recommended that Mobilux EP2 grease be used to lubricate the monitor gearing.



Caution: DO NOT use high pressure spray to clean the Nitro HD. Using high pressure spray can damage seals and lead to serious damage of electrical components.

At times the Nitro System may not provide the intended or expected operation. The following section is meant as a guide to the end user to help alleviate issues and improve the overall customer experience. Although Elkhart Brass is always willing and ready to address customer concerns, the customer is urged to refer to this troubleshooting guide before contacting Elkhart Brass for further support to ensure that system downtime is minimized as much as possible. If a solution cannot be found, please feel free to contact Elkhart Brass for further support.



Caution: Before attempting to view or adjust system wiring, disconnect the system from its power source.

Monitor & Nozzle will not function:

- Check to see if the fuse in the positive power lead to the Nitro System is blown. If this is the case, investigate incoming power of the chosen supply before replacing the fuse and attempting to operate the Nitro System again.
- Check that all wiring is connected as described in the installation section of this manual and that proper power and ground connections have been made to an appropriate power source.
- Inspect all system wiring for damage and for unseated pins or sockets in the Deutsch connections.
- Check that the power being supplied from the Power source is above 10.0 VDC. A supply voltage less than this at the Nitro Module will not successfully power the system on.

Nozzle will not move / moves intermittently:

View the nozzle while attempting to actuate the nozzle. If the actuator moves (3/4" override nut spins), but the nozzle tip does not move, there may be an obstruction in the nozzle.

- Inspect the nozzle for signs of debris or buildups that may be preventing nozzle movement from occurring. Remove all obstructions and debris.
- Check that the bellows covers are still being held in place. If the bellows covers are still properly in place, do not remove them.
- If the bellows covers have become unseated, locate an appropriate zip tie fastener and secure the bellows covers back into their original location.

If the nozzle actuator does not move when attempting to move the nozzle there could be an issue with the nozzle wiring or with the actuator motor.

- Inspect the nozzle actuator and monitor nozzle wires for damage. If any of these wires is damaged, the nozzle may not be receiving power.
- Check the gray 2-position Deutsch connection between the nozzle actuator and the monitor nozzle wire. Check the pins and sockets of this connection to ensure they have not become unseated, thus preventing them from making a proper connection.
- Check the green 12-position Deutsch connection under the monitor nameplate cover. Check the pins and sockets of this connection to ensure they have not become unseated, thus preventing them from making a proper connection.

Monitor will not move / moves intermittently / moves only in one axis:

- Operate the monitor manually to determine if there is a physical obstruction in the monitor gearing that could be preventing monitor movement.
- Inspect the monitor motor wires for damage. If any of these wires is damaged, the motors may not be receiving power.
- Inspect the sensor wires for damage. If any of these wires is damaged, the sensors may not be receiving power or correctly reporting to the Nitro Module. If a sensor is disconnected in any way or not reporting to the Nitro Module correctly, the Nitro System is programmed to shut down motion in that direction to prevent further damage to the system.
- Check the green 12-position Deutsch connection under the monitor nameplate cover. Check the pins and sockets of this connection to ensure they have not become unseated, thus preventing them from making a proper connection to the motors or sensors.

Nozzle is not flowing proper flow at rated pressure:

The 7000-EHD Nozzle is a fixed stem nozzle. Its flow and pressure profile will depend on the stem being used. Please refer to the flow chart in the specifications section for more detailed flow information. For more details on changing the stem of the 7000-EHD nozzle, please refer to the Operating Instructions section.

- Ensure that the correct stem is being used in the nozzle for the desired flow at the rated pressure. The stem's rated pressure and flow are listed on the flat face end of the stem and can be read with the nozzle fully assembled.
- Remove the nozzle from the monitor assembly and look inside to see if there is any debris lodged in the nozzle that would affect its flow. Remove any such obstructions.
- Ensure that the stream shapers are pushed as far as possible to the discharge end of the nozzle. Failure to push the stream shapers completely toward the nozzle discharge end will prevent the nozzle from flowing as intended.

SYSTEM SPECIFICATIONS

Nitro HD Monitor –

- Max Flow Rating 750 GPM
- Max Operating Pressure 250 PSI
- Inlet Size 2.5" NPT Female
- Outlet Size 2.5" NHT Male
- Travel V: 90° or 135°
H: Either 180° or 350°
- Weight 17 Lbs.
- Operating temperature range -40°F to +185°F (-40°C to +85°C)
- Environmental Rating NEMA 4 (Motors, Sensors, Wiring)

Nitro HD Motor Spec

Motor (12 VDC)	Left/Right	Up/Down	Nozzle
Run Current	5 A	5 A	0.5 A
Stall Current	70 A	70 A	NA
Current Trip Point	20 A	20 A	4 A

Table 1: Motor Current Specifications

7000-EHD Nozzle –

- Rated Flow 750, 500, 350, & 200 GPM depending on stem selection
- Rated Pressure 100 PSI
- Inlet Size 2.5" NHT Female
- Travel Straight Stream to Wide Fog
- Weight 6 Lbs.
- Environmental Rating NEMA 4

Nitro HD Module –

- Weight 0.25 Lbs.
- Environmental Rating NEMA 4
- Input Power 12/24 VDC
- Fuse Rating 20 Amps (12 VDC) & 10 Amps (24 VDC)

Nitro HD Joystick –

- Weight 1.8 Lbs. with enclosure
- Environmental Rating Not Sealed, intended for in-cab use ONLY

Nitro HD harness approximate weights and lengths –

- 37522000 (Module-to-Monitor) – 0.75 lbs, 15 feet
- 37523000 (Module-to-Joystick) – 0.5 lbs, 8 feet
- 37527000 (Joystick Extension) – 0.65 lbs, 15 feet

MONITOR AND NOZZLE HYDRAULIC DATA

Interpreting Flow Data

The following graphs offer the pressure losses for the monitor (and other devices) in terms of Total Static Pressure Drop. This Total Static Pressure Drop can be found by measuring the difference between the static inlet pressure and the static outlet pressure. The static pressure at either of these points can be found using a simple pressure gauge. An illustration of this method can be seen below.

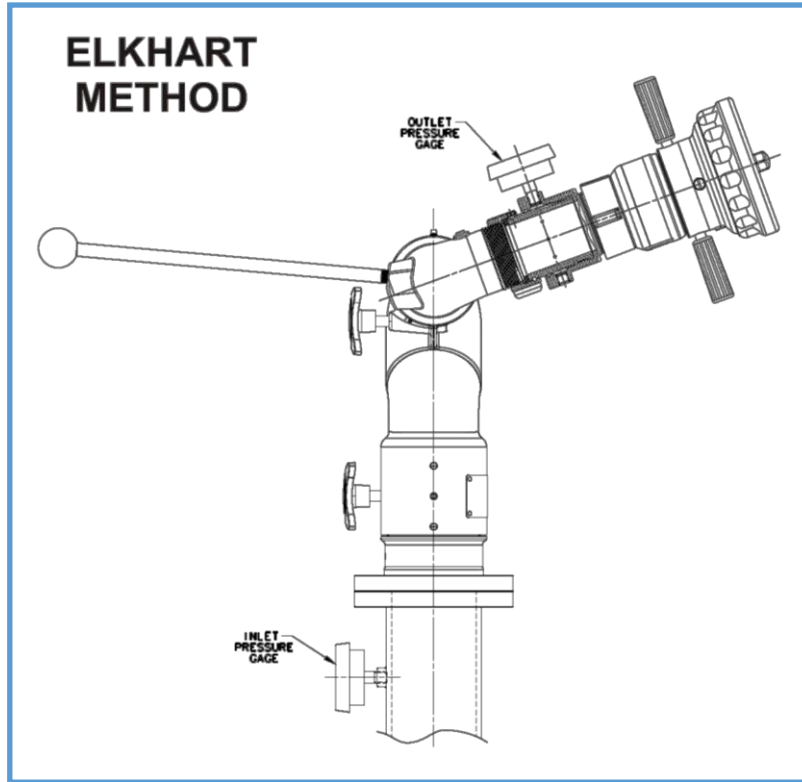

In mathematical terms, the Total Static Pressure Drop is the change in Velocity Pressure plus Friction Loss. The change in Velocity Pressure results from the change in velocity of water caused by the change in the cross section of a waterway. Friction Loss results from the drag and sidewall interference of the water through a device. A simple equation can be seen below.

$$\Delta P_S = H_F + \Delta P_V$$

ΔP_S = Total Static Pressure Drop
 H_F = Friction Loss
 ΔP_V = Velocity Pressure Loss

In the firefighting industry, the terms Total Static Pressure Drop and Friction Loss tend to be used interchangeably. However, these are significantly different measurements. This misconception could ultimately lead to lower than anticipated performance from equipment. When designing a system and determining performance, Total Static Pressure Drop is the value that should always be used. The Friction Loss curve is also supplied in order to make a comparison with competitor products that may only supply Friction Loss curves. If there are any further questions regarding this matter, please contact Elkhart Brass.

Nitro HD Monitor Pressure Drop (2.5" Inlet, 2.5" Outlet)

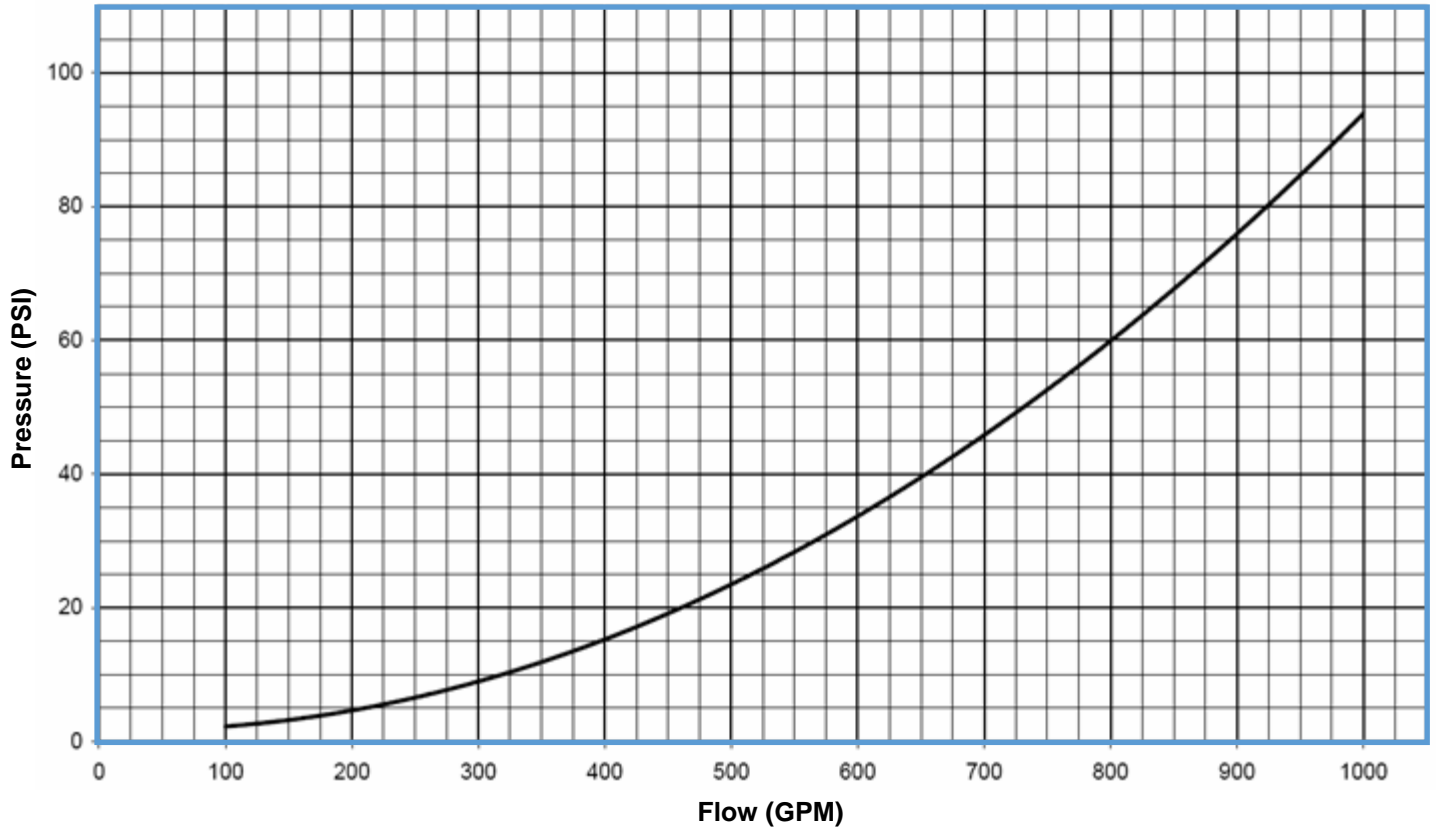

7000-EHD Nozzle Pressure vs. Flow

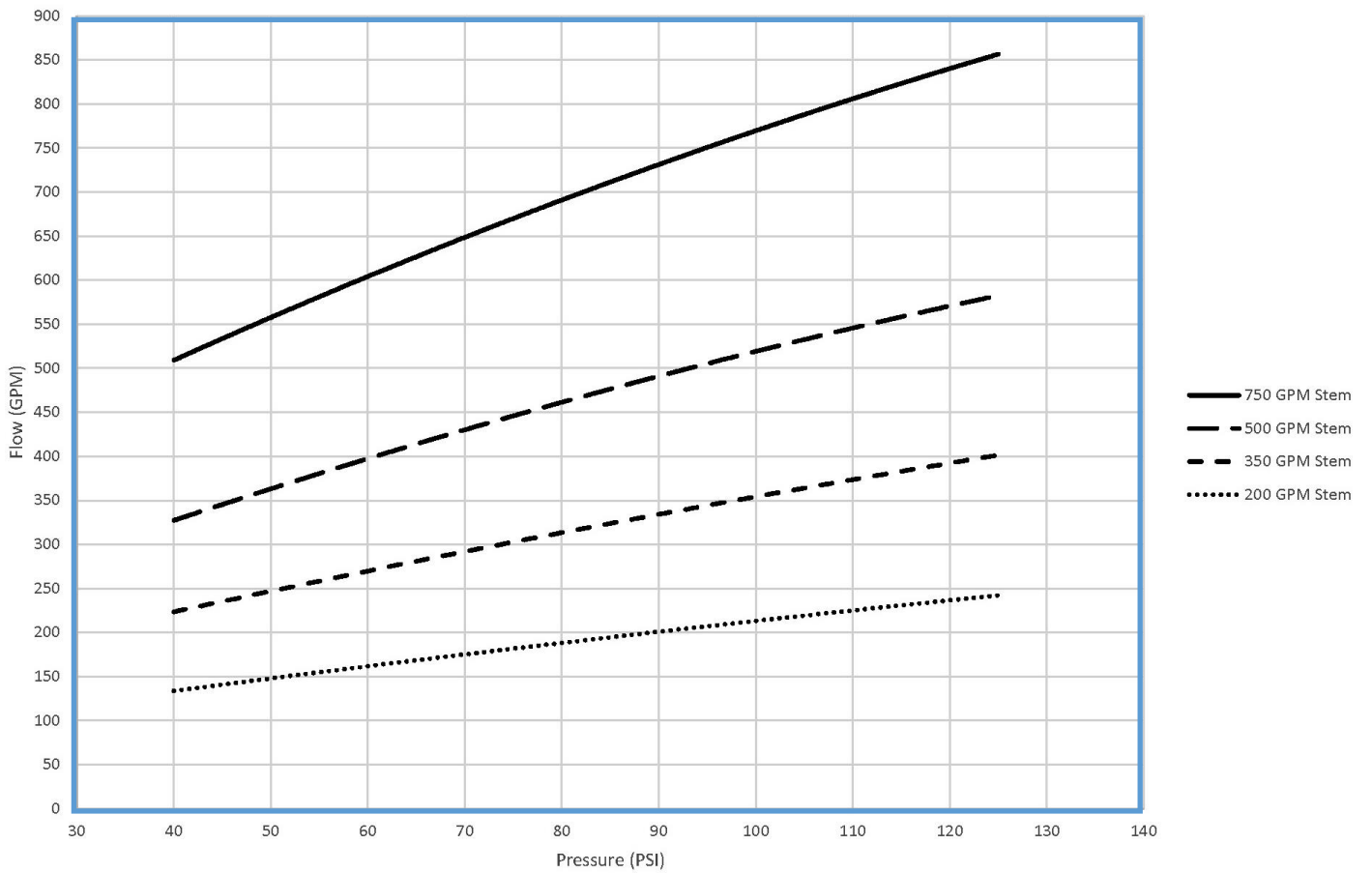

COMPONENT MOUNTING TEMPLATES

NOTE: Pages must NOT be scaled during printing or template size will be scaled incorrectly.

Nitro HD Module -

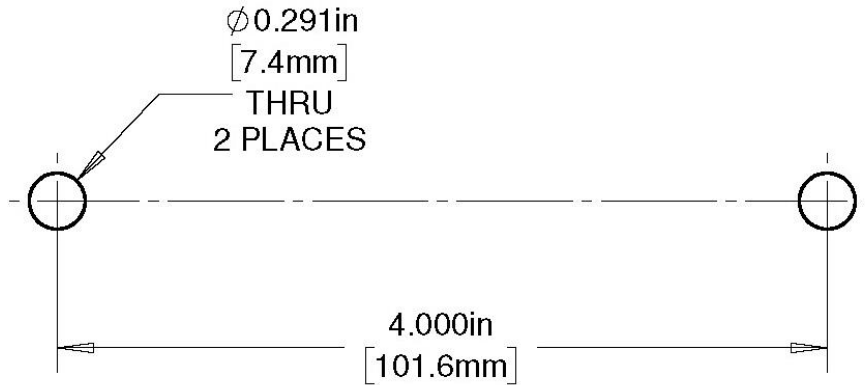

Nitro HD Joystick – (Panel top mounting, with enclosure)

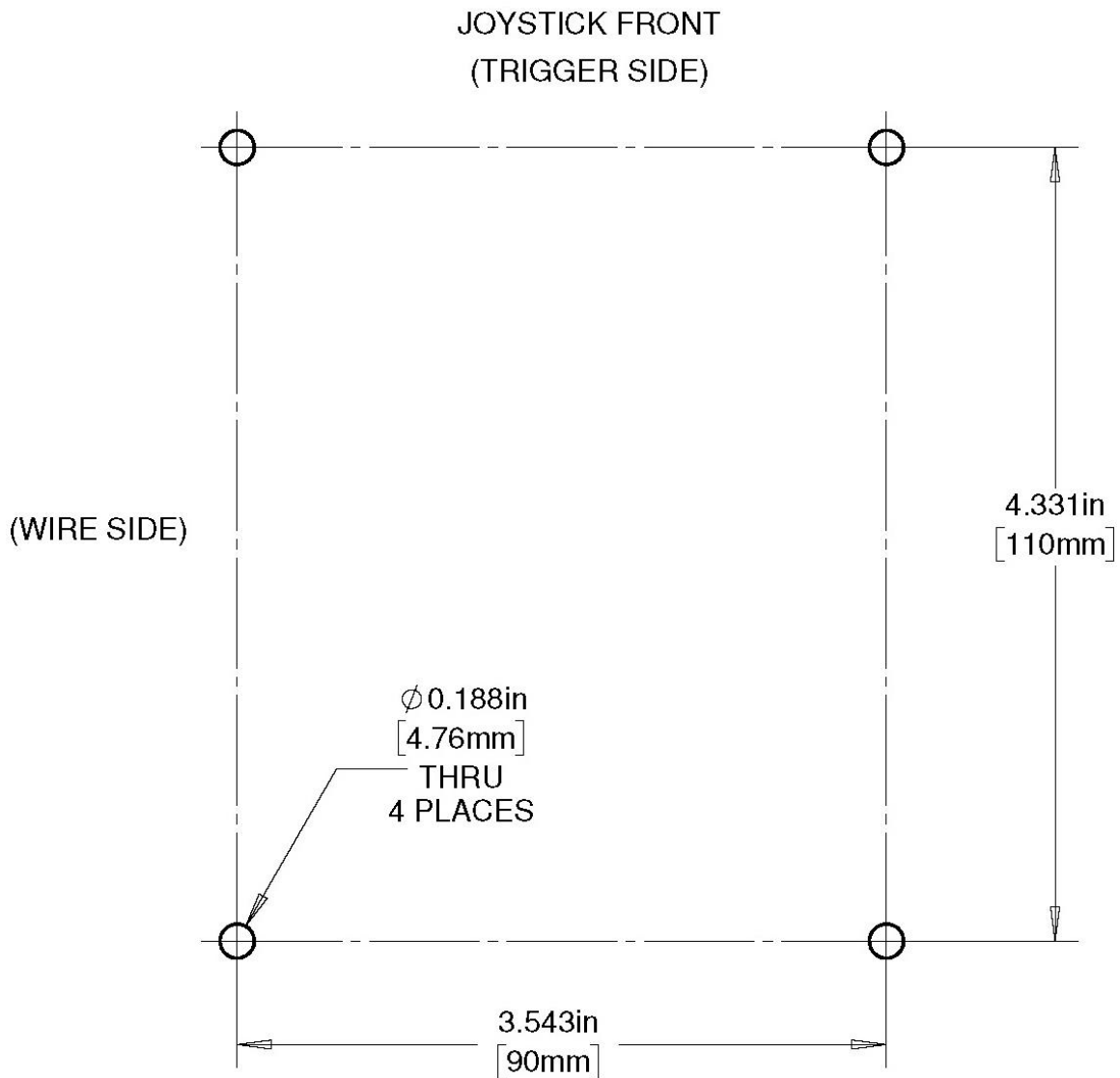

IF YOU CAN SEE THIS TEXT, PLEASE REPRINT THIS PAGE AT 100% (NOT SCALED) FROM THE DIGITAL PDF. DOUBLE CHECK BEFORE DRILLING.

IF YOU CAN SEE THIS TEXT, PLEASE REPRINT THIS PAGE AT 100% (NOT SCALED) FROM THE DIGITAL PDF. DOUBLE CHECK BEFORE DRILLING.

Nitro HD Joystick – (Flush with panel, enclosure removed)

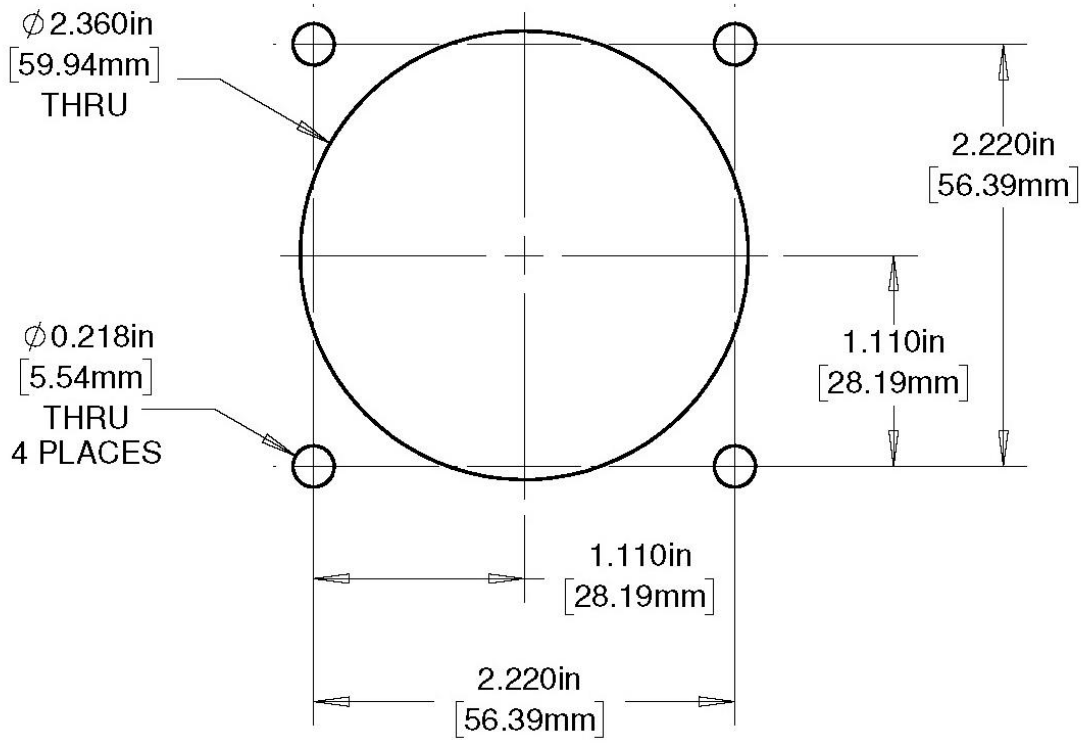

IF YOU CAN SEE THIS TEXT, PLEASE REPRINT THIS PAGE AT 100% (NOT SCALED) FROM THE DIGITAL PDF. DOUBLE CHECK BEFORE DRILLING.

IF YOU CAN SEE THIS TEXT, PLEASE REPRINT THIS PAGE AT 100% (NOT SCALED) FROM THE DIGITAL PDF. DOUBLE CHECK BEFORE DRILLING.



ELKHART BRASS
1302 WEST BEARDSLEY AVE • ELKHART, IN 46514
PHONE: 1-574-295-8330 • 1-800-346-0250
FAX: 1-574-293-9914
WWW.ELKHARTBRASS.COM

© ELKHART BRASS MFG. CO., INC. 2017

8100 NITRO HD MONITOR
INSTALLATION, OPERATION, AND MAINTENANCE INSTRUCTIONS
98568000 REV. B
